

## Bus Coupler CAN DeviceNet

## RIO-P BC CAN DN

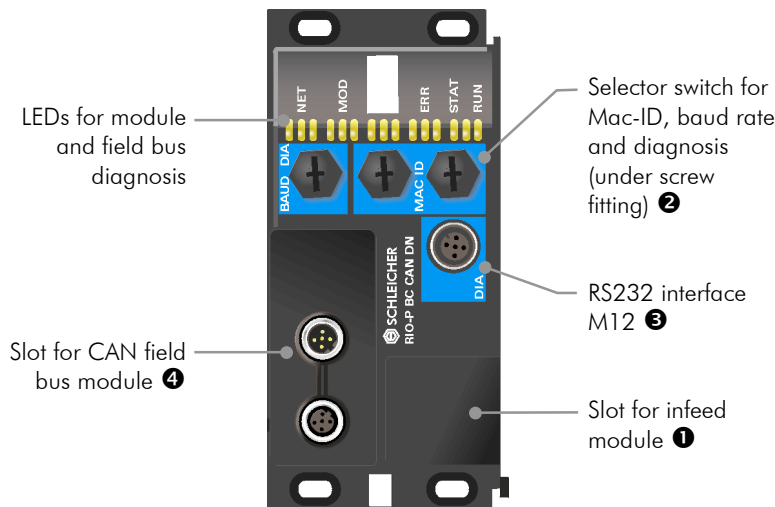

### Block diagram

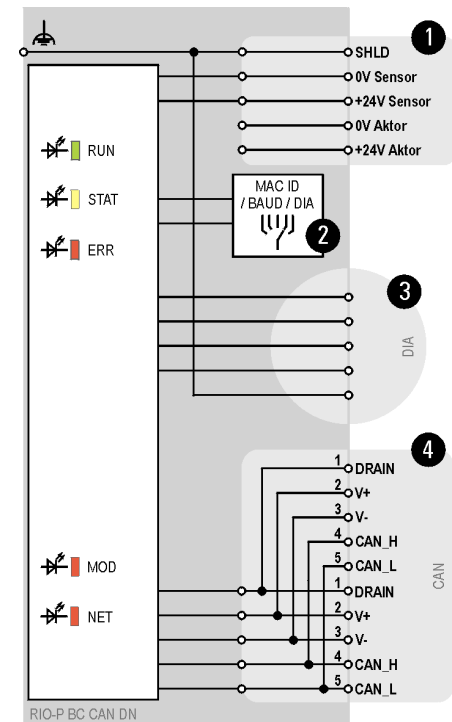

The RIO-P BC CAN DN bus coupler forms the interface between the CAN DeviceNet field bus and module communication to the I/O modules. A bus node comprises the bus coupler and up to eight expansion modules with 64 digital channels.

In order to achieve compatibility with various PLC standards you can use the byte-swap function to swap the two bytes of a data word.

The RIO-P BC CAN DN bus coupler offers not only run mode but also other modes for commissioning, diagnosis and comprehensive service functions. These are operated via the RIO.worx software tool. On controllers with a shortage of address space the diagnosis range can be switched off. This reduced the data width for transmission by 4 bytes.

Technical Data	RIO-P BC CAN DN
Article number	383 382 70
Field bus	CAN DeviceNet
Mac-ID	Address range 0 ... 63, setting via rotary switches
Baud rate	Up to 500 Kbaud, setting via rotary switches
Diagnosis interface	Switch on/off via rotary switches
Max. I/O range internal	64 bytes input data 64 bytes output data
External supply voltage	DC 24 V (±20%, max. 5% residual ripple)
Power supply to CAN interface	DC 11 ... 30V (meets CAN specification)
Power consumption	Bus coupler: < 2.5 W from external 24 V supply Connected modules: max. 5 W via internal 5 V supply
Number of attachable I/O modules	8
Interfaces	
RS 232	External, for commissioning and system diagnosis
CAN DeviceNet	External, via field bus module RIO-P F CAN

For general technical data see next page

## Technical Data RIO Protected IP67

### Supply voltage

Operating voltage	24 V DC $\pm$ 20% max. 5% residual ripple
-------------------	---

### Connection system

Sensors / actuators	M12 connectors 5-pin
Field bus	M12 connectors 5-pin
Supply voltage	Depending on infeed module: CA, 7/8" or M23

### Housing and installation

Type of protection	IP 67 to EN 60529
Dimensions (W x H x D)	70 x 140 x 45 mm (bus coupler and I/O modules)
Fixing	On electrically conductive surface with at least two diagonally opposed fixing points (for normal mechanical load) with M4 screws
Installation Position	Any

### Climatic conditions

Ambient operating temperature	0 ... +55°C (category KV to DIN 40040)
Storage temperature	-25 ... +70°C (category HS to DIN 40040)
Relative humidity	100%
Air pressure in operation	860 ... 1060 hPa

### Mechanical strength

Vibration	10 ... 57 Hz constant amplitude 0.075 mm 57 ... 150 Hz constant acceleration 1 g (to DIN IEC 68-2-6)
-----------	---

### Electromagnetic compatibility

Electrostatic discharge	EN 61000-4-2: 8 kV contact discharge
Electromagnetic fields	EN 61000-4-3: field intensity 10 V/m, 80 ... 1000 MHz
Burst	EN 61000-4-4: 2 kV on DC supply lines, 1 kV on I/O signal and serial interface lines
Interference emissions	EN 55011: Limit Category A, Group 1